



SN1·SN2 SERIES

C Frame Crank Press



TAIWAN
EXCELLENCE
1996



TAIWAN
EXCELLENCE
1999

FEATURES

- High torque, low noise wet clutch and brake.
- Rigid frame with less deflection.
- High accuracy transmission gears and high rigidity crank ensure press long life and accuracy.
- Forced Lubrication system with default monitor ensures the operation reliability.
- User-friendly design and all-function electric control system provide high automation compatibility.





High Quality Crank Shaft

The strong crank shaft with outstanding rigidity ensures that accuracy can be maintained under qualified standard and extends the life of tooling.



High Precision Transmission Gear

The highly accurately machined gear system provides smooth and silent operation.

High Torque Wet Clutch and Brake

- Multi-plate, low inertial design for quick response operation.
- High intermittent allowance for robot automatic operation.
- No pollution and low noise correspond the future environmental requirement.

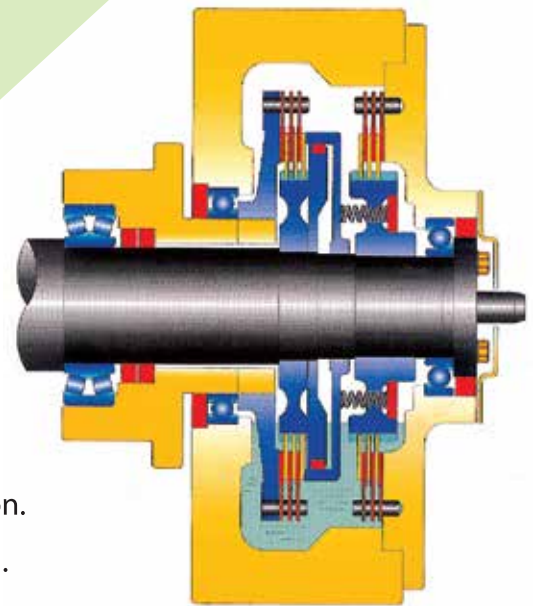

FEATURES



Auto Lubrication System

The auto lubrication system with default monitor ensures high reliable operation.



HMI Interface

User-friendly design for simple and easy operation.

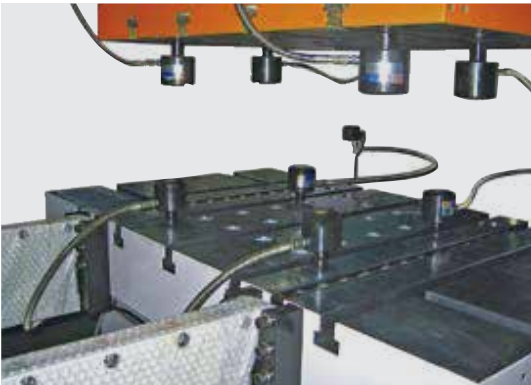
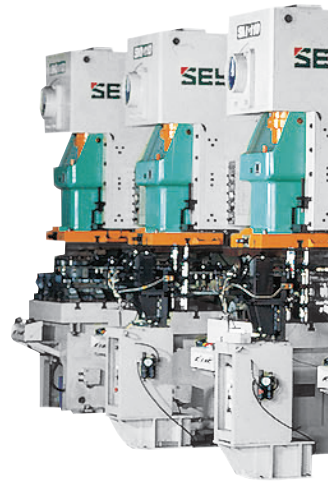

Quick Die Change Device (Option)

The die lifter, die clamp and auxiliary rails allow to carry out die changing easily in a short time.

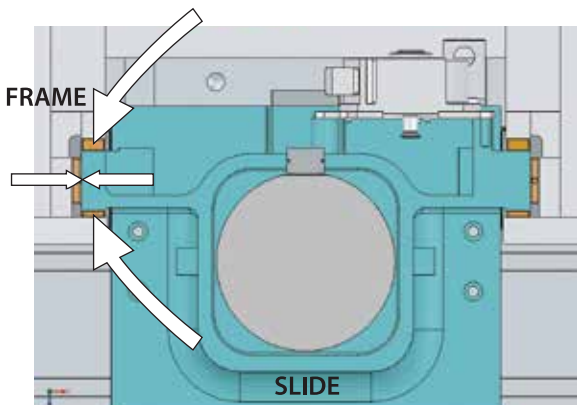

Long 6-Side Gibs

Durable alloy brone lining fixed directly on the frame without the defect of loosing adjusting bolts. Durable lining can also maintain high accuracy and extend the life of tooling.

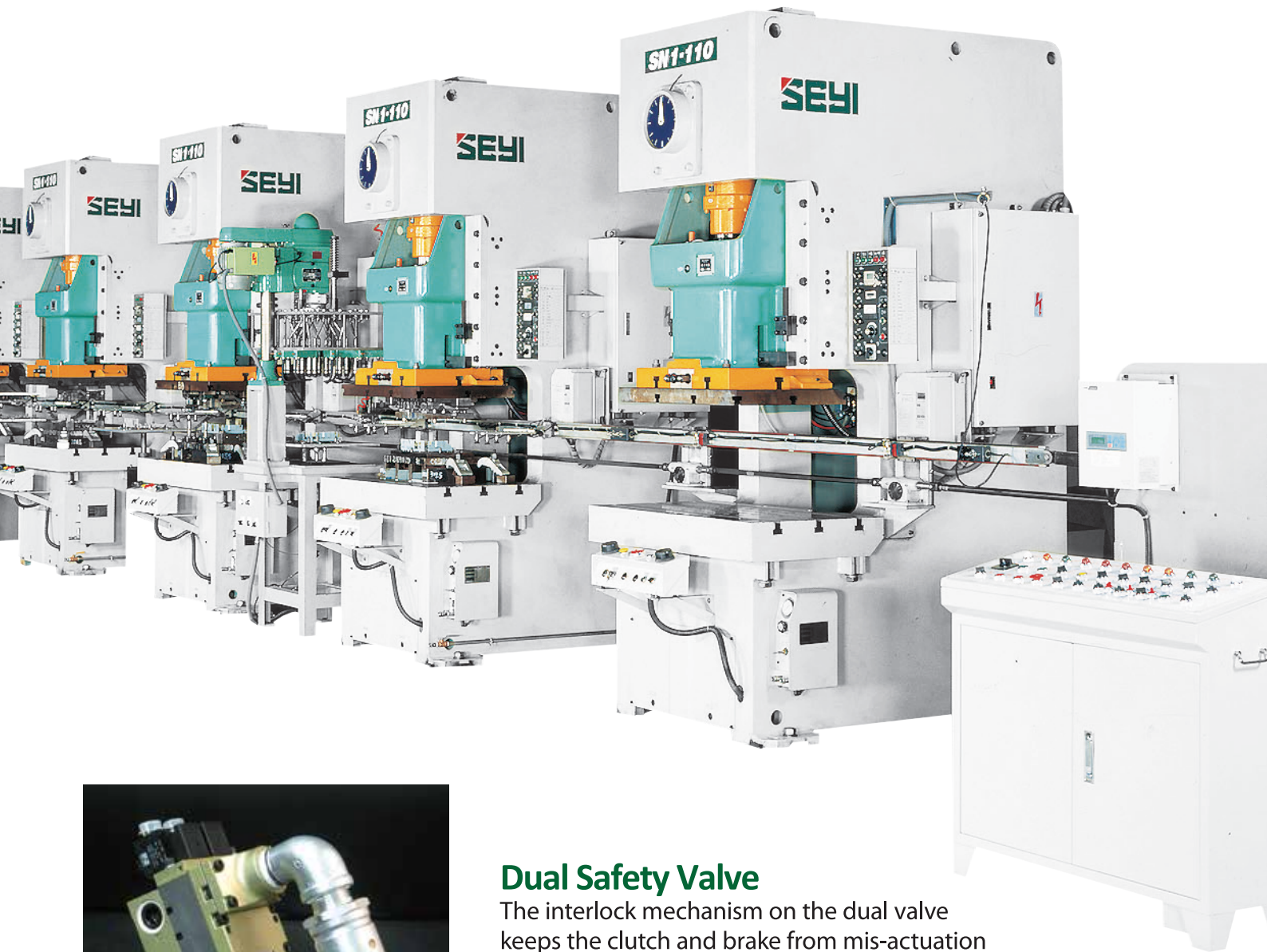

Dual Safety Valve

The interlock mechanism on the dual valve keeps the clutch and brake from mis-actuation when valve is default.

Hydraulic Overload Protection

The hydraulic overload protection is installed to prevent the overloading from exceeding the rating capacity tonnage and protect press and tooling from damage. The simple resetting process makes the restart operation easily.

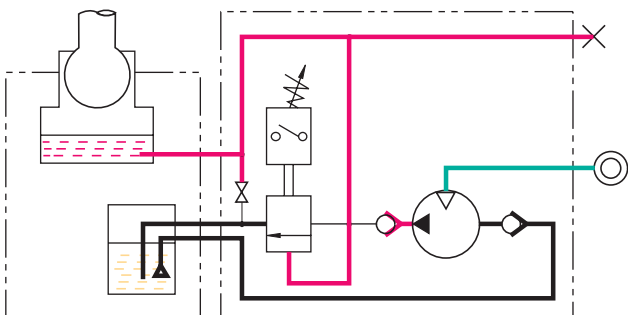

SN1 series

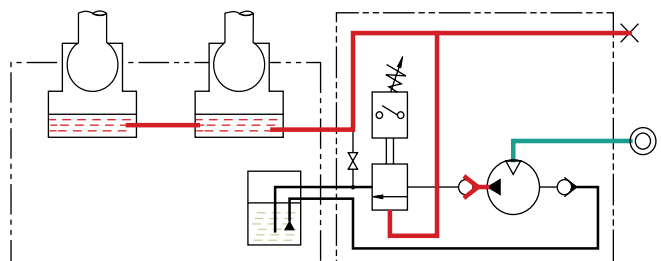

SN2 series

FEATURES



Easy-to-use Slide Adjusting Device

(**SN1-25~45 only)

Simple, reliable manual slide adjuster with 0.1mm increment indicator.



Motorized Slide Adjusting Device

(** SN1-25~45 not applicable)

The motorized slide adjusting device is adopted with a thin brake motor and operated with push buttons. It provides stable positioning accuracy and quick adjustment.



Digital Die Height Indicator

(** SN1-25~45 not applicable)

Motorized slide adjusting device fitted with 0.1mm increment digital die height indicator.

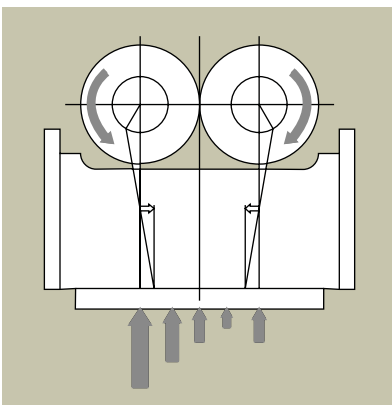

Eliminated Side Thrust

(**SN2 series only)

Opposed rotation design to minimize the side thrust force.

SN1 SERIES

Standard Attachments

- Main Motor with Inverter
 - Main Motor FWD/REV Controller
 - Combination Wet Clutch / Brake
 - Hydraulic Overload Protection
 - Counter Balance
 - Anti-Repeat Safety Circuit
 - Misfeed Socket- 4 Sets (2A, 2B)
 - Air Ejector – 1 Set
 - Air Outlet - 1 Set
 - Tool Box
 - Spare Cam - 4 sets
 - Job Storage Capacity - 99 sets
 - Manual Slide Adjustment (SN1-25~45)
 - Die Height Indicator (SN1-60~250)
 - Motorized Slide Adjustment (SN1-60~250)
 - PPC 9100 Control System (Touch Panel HMI)
 - To Display SPM and Crank Angle
 - To Display Running Status and Error Message
 - Total/Preset/Batch/Maintenance Counter
-

Optional Attachments

- Anti Vibration Mounts
 - Lamp Socket (1A)
 - Bottom Dead Center Detector
 - Quick Die Change System
 - Safety Light Curtain
 - Knockout Device
 - Power Take-off Shaft
 - Portable Operator Stand
 - Adjustable Single Shot Lubrication
 - Safety Block
 - Die Lamp
 - Pneumatic Die Cushion
 - Power Consumption Management
 - SPM Input via HMI
-

SN2 SERIES

Standard Attachments

- Main Motor with Inverter
 - Main Motor FWD/REV Controller
 - Combination Wet Clutch / Brake
 - Hydraulic Overload Protection
 - Portable Operator Stand
 - Anti-Repeat Safety Circuit
 - Die Height Indicator
 - Counter Balance
 - Motorized Slide Adjustment
 - Misfeed Socket- 4 Sets (2A, 2B)
 - Air Ejector – 1 Set
 - Air Outlet - 1 Set
 - Tool Box
 - Spare Cam - 4 sets
 - Job Storage Capacity - 99 sets
 - PPC 9100 Control System (Touch Panel HMI)
 - To Display SPM and Crank Angle
 - To Display Running Status and Error Message
 - Total/Preset/Batch/Maintenance Counter
-

Optional Attachments

- Anti Vibration Mounts
- Lamp Socket (1A)
- Bottom Dead Center Detector
- Quick Die Change System
- Safety Light Curtain
- Knockout Device
- Power Take-off Shaft
- Booster
- Adjustable Single Shot Lubrication
- Safety Block
- Die Lamp
- Pneumatic Die Cushion
- Power Consumption Management
- SPM Input via HMI

Model		SN1-25			SN1-35			SN1-45			SN1-60			SN1-80			SN1-110			SN1-160			SN1-200			SN1-250								
Type		S	H	P	S	H	P	S	H	P	S	H	P	S	H	P	S	H	P	S	H	P	S	H	P	S	H	P						
Tonnage Capacity	kN	250			350			450			600			800			1100			1600			2000			2500								
Stroke Length (D)	mm	80	50	35	90	60	40	110	70	45	130	80	50	150	100	60	180	110	70	200	130	80	220	150	90	250	180	100						
Stroke per Minute	Fixed speed	90	110	140	80	100	130	70	90	120	60	80	100	60	80	100	50	70	90	40	60	80	35	50	65	30	45	55						
	Variable speed	70~110	80~140	80~180	60~95	70~130	80~170	50~85	60~120	80~160	40~75	55~110	70~150	40~75	50~100	65~140	35~65	45~90	60~125	30~50	35~70	50~100	25~45	30~60	40~85	22~40	30~50	30~70						
Tonnage Rating Point	mm	3.2		2.3	3.2		2.3	3.2		2.3	4		2.3	5			3.2	5			3.2	6			4	6			4					
Die Height (D,H)	mm	230	200	200	250	220	220	270	240	240	300	270	270	330	300	300	350	320	320	400	360	360	450	400	400	450	400	400						
Slide Adjustment (G)	mm	50			50			60			70			80			90			100			110			120								
Slide Area (PxQ)	mm	330x250			380x300			430x350			480x400			560x460			650x520			720x580			860x650			960x720								
Diameter of Shank Hole	mm	ø38.1			ø50.8			ø50.8			ø50.8			ø50.8			ø50.8			ø65			ø65			ø65								
Bolster Area (ExF)	mm	700x320			780x400			840x440			900x520			1050x600			1150x680			1250x760			1400x840			1500x900								
Bolster Thickness (T)	mm	85			100			115			130			140			155			165			180			180								
Bolster Height (Z)	mm	800			800			800			900			900			900			900			1000			1000								
Frame - Inside Distance (R)	mm	388			486			516			544			614			670			730			900			970								
Frame - Gap Distance (K)	mm	170			210			230			270			310			350			390			430			460								
P.T.O. Shaft Position (CxSxU)	mm	351x983x383			403x1068x405			428x1158x437			450x1285x478			507x1445x512			596x1630x614			646x1809x686			756x2067x726			796x2262x844								
Main Motor	Fixed speed	3.7x4			3.7x4			3.7x4			5.5x4			5.5x4			7.5x4			7.5x4			11x4			11x4			15x4			15x4		
	Variable speed	3.7x4			3.7x4			3.7x4			5.5x4			5.5x4			7.5x4			7.5x4	11x4		11x4	15x4		15x4			18.5x4					
Slide Adjustment Motor	kWxP	—			—			—			0.4x4			0.4x4			0.4x4			0.4x4			0.7x4			0.7x4			0.7x4					
Foot Print (AxB)	mm	720x1058			830x1125			890x1210			940x1315			1050x1480			1160x1680			1300x1985			1480x2113			1560x2400								
Position of Anchor Bolts(MxN)	mm	620x878			730x925			790x1010			840x1115			950x1230			1060x1380			1180x1655			1360x1753			1440x2000								
Required Floor Space (WxL)	mm	875x1335			985x1400			1035x1485			1085x1620			1195x1785			1310x1985			1510x2290			1690x2415			1770x2705								
Press Height (w/o Mounts) (H)	mm	2060			2185			2290			2540			2755			2990			3270			3725			4005								
Required Air Pressure	MPa	0.55			0.55			0.55			0.55			0.55			0.55			0.55			0.55			0.55								
Die Cushion (Option)																																		
Capacity	kN	22	—	—	22	—	—	35	—	—	35	—	—	60	—	—	80	—	—	100	—	—	140	—	—	140	—	—						
Stroke Length	mm	50	—	—	50	—	—	70	—	—	70	—	—	80	—	—	90	—	—	100	—	—	110	—	—	120	—	—						
Die Cushion Area (LRxFB)	mm	295x210	—	—	295x210	—	—	340x234	—	—	340x234	—	—	410x260	—	—	480x300	—	—	540x340	—	—	640x440	—	—	740x540	—	—						

Machine Dimension

SN1-160, 200, 250 are without shank holder

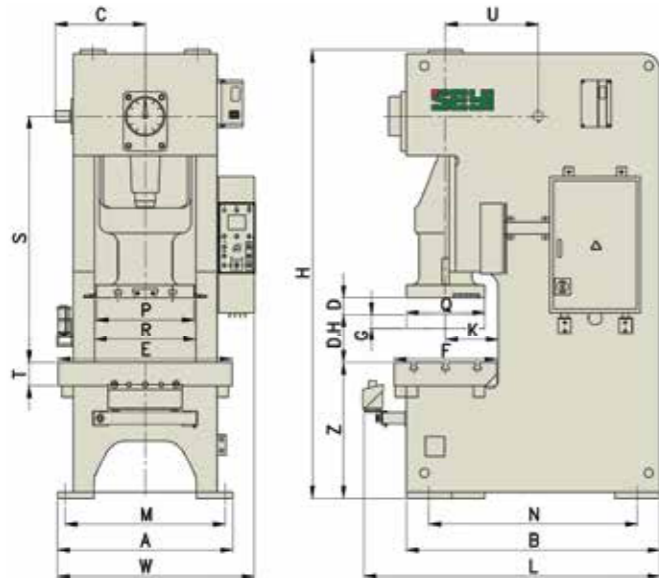

Dimension of Bolster Plate and Ram

The cushion pin holes of SN1-25, 35, 45, 60, 200 are center located on bolster

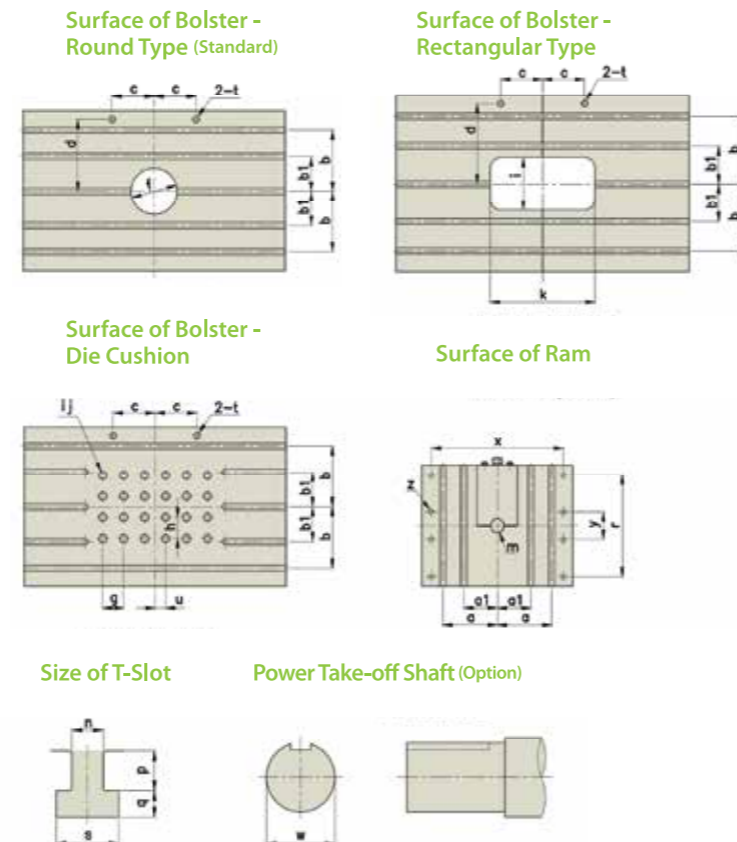

Model	SN1-25	SN1-35	SN1-45	SN1-60	SN1-80	SN1-110	SN1-160	SN1-200	SN1-250	
a	105	130	140	150	160	180	260	300	350	
a1	—	—	—	—	—	—	160	170	200	
b	100	125	140	150	180	210	290	320	350	
b1	—	—	—	—	—	—	165	180	200	
c	130	130	150	150	150	150	200	200	250	
d	135	170	185	200	250	300	340	380	410	
e	—	210	220	240	270	280	290	320	320	
f	ø100	ø110	ø130	ø150	ø180	ø200	ø220	ø250	ø270	
g	65	65	75	75	75	90	100	100	100	
h	60	90	100	100	75	90	100	100	100	
i (LRxFB)	5x3	5x3	5x3	5x3	6x4	6x4	6x4	7x5	8x6	
j	ø26	ø26	ø26	ø26	ø26	ø32	ø32	ø32	ø32	
k	200	220	260	300	360	400	440	500	540	
l	100	110	130	150	180	200	220	250	270	
m	ø38.1	ø50.8	ø50.8	ø50.8	ø50.8	ø50.8	ø65	ø65	ø65	
n	22	22	22	22	28	28	28	28	28	
p	23	23	23	23	30	30	30	30	30	
q	16	16	16	16	20	20	20	20	20	
r	—	—	—	—	—	—	480	550	620	
s	38	38	38	38	48	48	48	48	48	
t	ø22	ø26	ø26	ø30	ø30	ø30	ø30	ø30	ø30	
u	0	0	0	0	37.5	45	50	0	0	
w	ø35 -0 -0.03	ø35 -0 -0.03	ø40 -0 -0.03	ø40 -0 -0.03	ø40 -0 -0.03	ø40 -0 -0.03	ø70 -0 -0.03	ø70 -0 -0.03	ø70 -0 -0.03	ø70 -0 -0.03
x	290	340	370	400	480	560	630	750	850	
y	70	70	80	90	90	100	130	140	160	
z	4-ø18	4-ø18	4-ø18	4-ø18	4-ø18	4-ø23	4-ø23	4-ø23	4-ø23	

PS. : The T-Slot on slide only for SN1-160 above.

※ This specifications is subject to change without notice.

Model		SN2-110		SN2-160		SN2-200		SN2-250		SN2-300	
Type		S	H	S	H	S	H	S	H	S	H
Tonnage Capacity	kN	1100		1600		2000		2500		3000	
Stroke Length (D)	mm	180	110	200	130	230	150	250	180	280	180
Stroke per Minute	Fixed speed	50	70	40	60	35	50	30	45	30	45
	Variable speed	35~65	45~90	30~50	35~70	25~45	30~60	22~40	30~50	20~35	30~50
Tonnage Rating Point	mm	5		6		7		7		7	
Die Height (D,H)	mm	400	350	450	400	500	450	550	450	550	450
Slide Adjustment (G)	mm	90		100		110		120		120	
Slide Area (PxQ)	mm	1430x520		1560x580		1850x650		2100x700		2100x800	
Diameter of Shank Hole	mm	ø51x3		ø51x3		ø51x3		ø51x3		ø51x3	
Bolster Area (ExF)	mm	1880x680		2040x760		2420x840		2700x920		2700x940	
Bolster Thickness (T)	mm	150		160		170		180		200	
Bolster Height (Z)	mm	900		950		1000		1100		1100	
Frame - Inside Distance (R)	mm	1470		1590		1930		2190		2180	
Frame - Gap Distance (K)	mm	350		390		430		470		480	
P.T.O. Shaft Position (CxSxU)	mm	1005x1685x615	1005x1600x615	1085x1855x660	1085x1770x660	1260x2107x710	1260x2017x710	1405x2305x770	1405x2170x770	1420x2435x800	1420x2285x800
Main Motor	kWxP	7.5x4	11x4	11x4	15x4	15x4	15x4	22x4	22x4	22x4	22x4
Motor of Slide Adjustment	kWxP	0.7x4		1.5x4		1.5x4		1.5x4		1.5x4	
Foot Print (AxB)	mm	1960x1760	1960x1705	2170x2030	2170x1970	2520x2165	2520x2115	2810x2470	2810x2395	2840x2570	2840x2470
Position of Anchor Bolts(MxN)	mm	1860x1410	1860x1355	2050x1590	2050x1530	2400x1725	2400x1675	2690x1970	2690x1895	2720x2035	2720x1935
Required Floor Space (WxL)	mm	2190x1810	2190x1810	2375x2085	2375x2085	2725x2230	2725x2230	3015x2530	3015x2530	3045x2600	3045x2600
Press Height(w/o Mounts)(H)	mm	3110	3025	3380	3295	3760	3670	4150	4015	4380	4230
Required Air Pressure	MPa	0.55		0.55		0.55		0.55		0.55	
Die Cushion (Option)											
Capacity (at 0.55MPa)	kN	60x2	—	80x2	—	100x2	—	140x2	—	140x2	—
Stroke Length	mm	95	—	110	—	130	—	140	—	140	—
Die Cushion Area (LRxFB)	mm	480x340x2	—	560x370x2	—	700x450x2	—	700x450x2	—	700x450x2	—

Machine Dimension

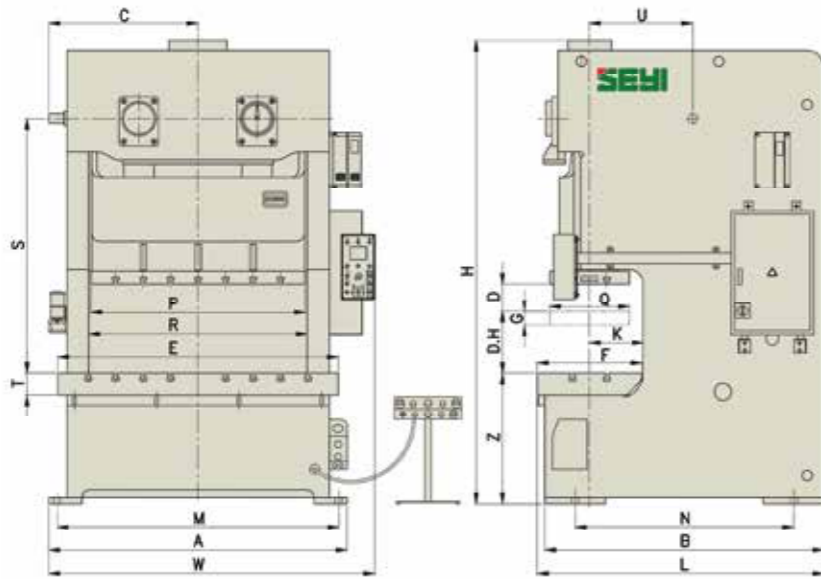

Dimension of Bolster and Slide

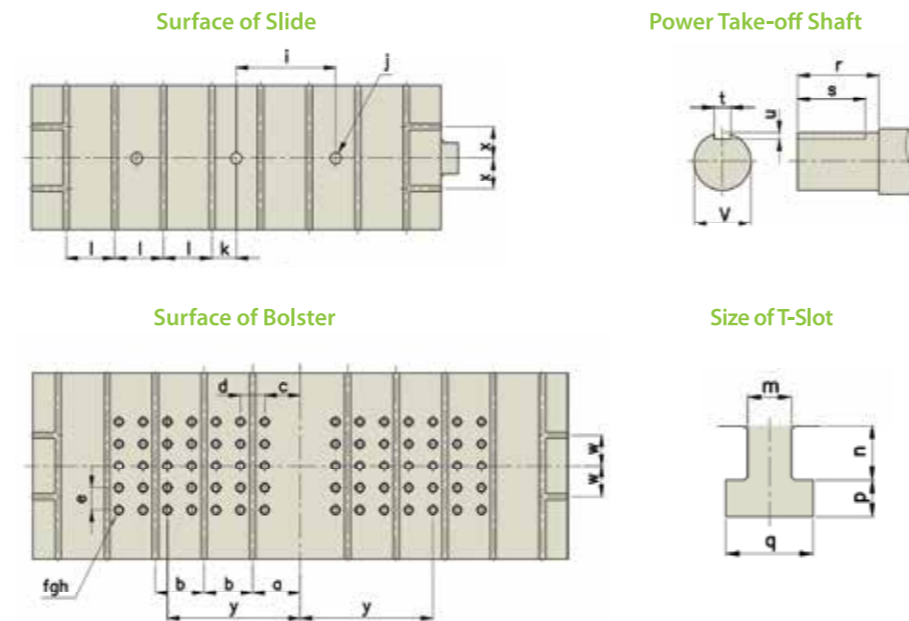

Model	SN2-110	SN2-160	SN2-200	SN2-250	SN2-300
a	110	200	215	235	235
b	200	200	220	220	220
c	160	150	160	180	180
d	100	100	110	110	110
e	100	100	100	100	100
f (LRxFB)	5x4x2	6x4x2	7x5x2	7x5x2	7x5x2
g	ø32	ø32	ø32	ø32	ø32
h	ø40	ø40	ø40	ø40	ø40
i	350	400	450	450	450
j	ø51	ø51	ø51	ø51	ø51
k	120	0	110	120	120
l	240	200	220	240	240
m	28	28	28	28	28
n	30	30	30	30	30
p	20	20	20	20	20
q	48	48	48	48	48
r	100	100	100	100	100
s	90	90	90	90	90
t	20	20	20	20	20
u	7.5	7.5	7.5	7.5	7.5
v	ø70 -0 -0.03	ø70 -0 -0.03	ø70 -0 -0.03	ø70 -0 -0.03	ø70 -0 -0.03
x	115	125	140	150	150
y	360	400	490	510	510

※ This specifications is subject to change without notice.



SHIEH YIH MACHINERY INDUSTRY CO., LTD. (HEADQUARTERS)

XIE YI TECH MACHINERY (CHINA) CO., LTD.

SEYI-AMERICA, INC.

SEYI México

SEYI PRESSES EUROPE GmbH

SEYI (Thailand) CO., LTD.

www.seyi.com

