

Entry models

into **CNC machining**



Vcenter-102E



Vturn-20E/26E

Victor Taichung - an established ISO-9001 & 14001 company



Vcenter-102E

Economic & reliable for mass production!

- Arm-type ATC
- Japanese-made linear motion guideways
- Meehanite® casting
- Victor Taichung's own spindle



Efficient tool changer

- Twin arm type ATC performs better overall continuous tool changes compared with disc type tool changer, while at the same time offering faster tool change - merely 3.5 seconds with BT-40 or CT-40 tooling.

Victor Taichung's own spindle

- The spindle is supported with angular thrust bearings for large contact areas that easily handles large axial and radial loads, while computer modeling helps determine bearing locations for maximum spindle stiffness.
- 8000 rpm spindle meets versatile machining demands.



Spindle Output Diagram

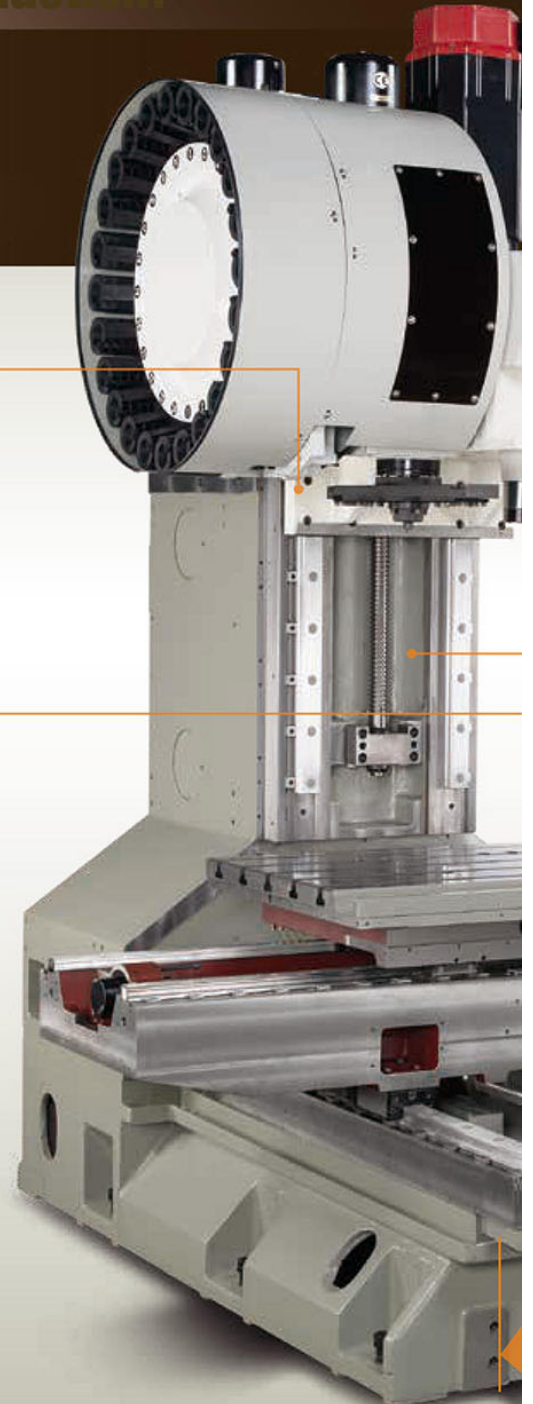
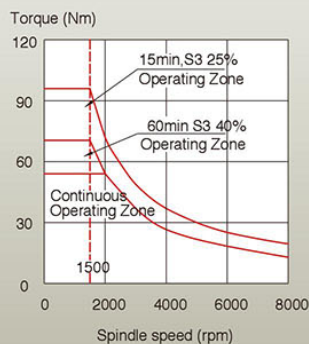
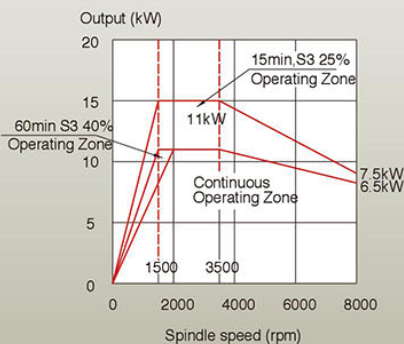

Minimizing the effects of thermal growth

- Symmetrical design and construction means heat generation is limited to minimize the effects of thermal growth on machine accuracies.
- Double-anchored ballscrews are pretensioned during assembly to absorb heat with minimal thermal growth.
- Effective chip evacuation from the machining area improves heat dissipation from the working area, while spindle oil cooling prevents excessive spindle growth.
- Spindle oil cooler (optional) can be installed to enhance the spindle durability for long time machining.

Strong machine structure

- Stiffness enhanced column with big triangle bottom offers the maximum cutting stability whenever this machine is used with rapid feed .
- Machine bed and saddle feature triangular cast structure to evenly distribute the machine loading, while cross diagonal ribbing in the column minimizes distortion and twisting during operation.
- All major structural components are made from Meehanite cast iron to ensure consistent homogenous castings.

MEEHANITE

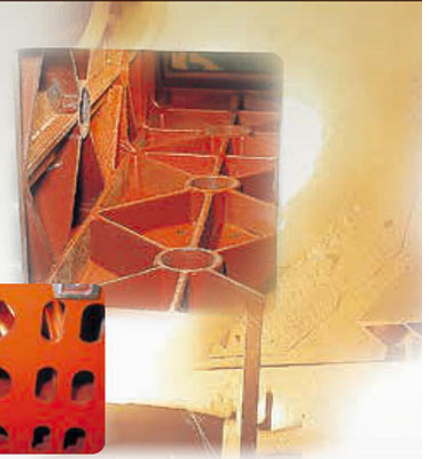

Coolants and chips disposal

- Coolants are injected around the spindle ring to avoid chip build-up on machined parts.
- High pressure coolant flushing away the swarf from the bottom guarding assures optimal chip disposal efficiency during machining.
- "Λ" type telescopic cover reduce the swarf accumulation.

Front mounted Y axis servo motor

- Superior structure stiffness with the optimal rail spacing 700 mm supports the long table at the travel end of X axis movement.
- THREE supporting blocks in each X-axis guide and 2 blocks in each Y-axis guide guarantees the accuracy requirement.
- The Y axis servo motor is front mounted to reduce the overall length of the ballscrew thus reducing the thermal displacement and increasing structure rigidity.
- Y-axis travel 600mm meets various machining requirements.

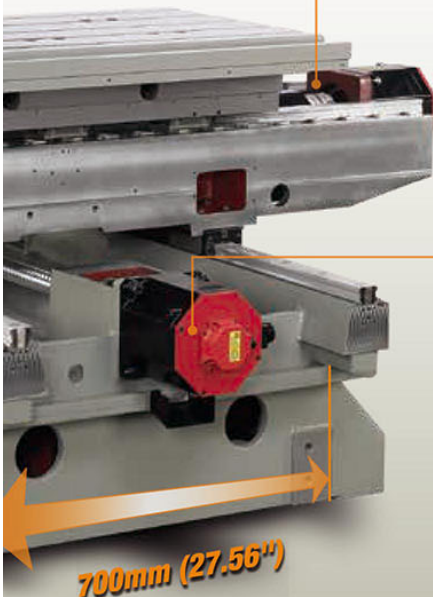

Vturn-20E / 26E

Economic & reliable for mass production!

- Genuine 45° slant bed with box slideways
- Z-axis ball screw diameter 40mm
- 8"/10" chuck for Vturn-20E/26E
- Programmable tailstock and chip conveyor



3-jaw Power chuck

- Renowned reliability chuck is foot operated for safety and easy operation.

High rigidity & high precision spindle

- Encased in well ribbed headstock for maximum heat dissipation.
- Angular thrust bearings absorb axial cutting force and NN-type roller bearings facilitate heavy cutting.

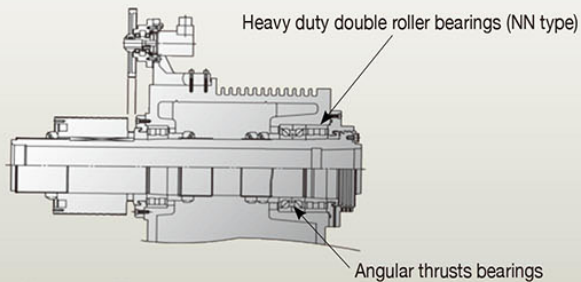

Spindle Output Diagram

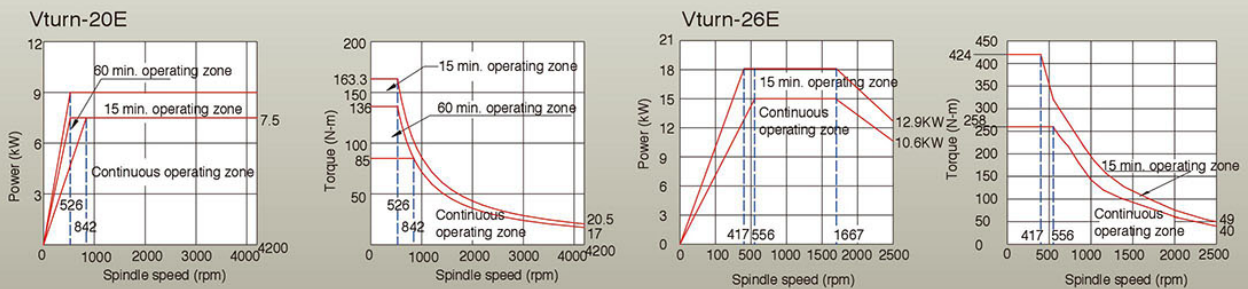

Hardened box slideways

- Box slideways even enhance the structure rigidity to afford intermittent cutting or hard material turning
- Hardness HRC 55 for heavy cutting
- Auto forced lubrication

Victor Taichung's own turret

- Hydraulic clamping for high rigidity
- Curvic coupling for high accuracy

Genuine 45° slant bed

- Vturn-20E/26E lathes have the Z-axis ballscrew mounted on the slant bed (P1) instead of machine base (P2) to minimize the distance from ballscrew to the tool insert and thus upgrades the turret and carriage stiffness.
- Meehanite® certificated casting

Programmable tailstock

- Smooth tow-along action by turret and programmable by M-code control

Coolant and chip disposal

- Front removed coolant tank for easy chip clean-up
- High pressure coolant (1.1 bars/50Hz, 1.5 bars/60Hz) is offered as standard and optional 3.3 bars is available.

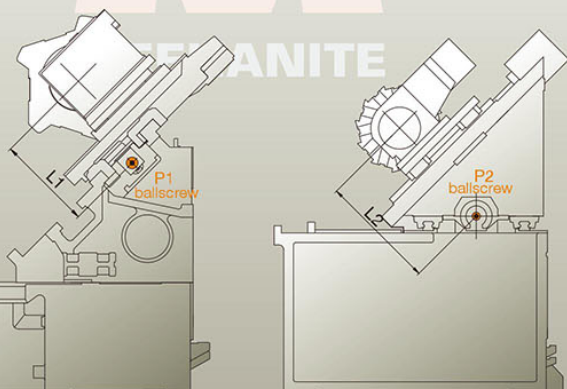

VICTOR's FANUC Oi-MF type 3

Control Specifications

Standard

ITEM	SPECIFICATION	DESCRIPTION
Controlled Axes		
1.	Controlled Axes	3 Axes (X, Y, Z)
2.	Simultaneous Controlled Axes	Position, Linear Interpolation/Circular Interpolation (3/3/2)
3.	Least Input Increment	0.001 mm / 0.0001 inch / 0.001 deg
4.	Least Input Increment 1/10	0.0001 mm / 0.00001 inch / 0.0001 deg
5.	Max. command value	+99999.999 mm (+9999.9999 in)
6.	High Speed HRV Control	Std.
7.	Inch / Metric Conversion	Std. (G20 / G21)
8.	Interlock	All Axes / Each Axis / Cutting Block Start
9.	Machine Lock	All Axes / Each Axis
10.	Emergency Stop	Std.
11.	Over-travel	Std.
12.	Stored Stroke Check 1 and Check 2	Std.
13.	Mirror Image	Each Axis
14.	Mirror Image M73, M74, M75, M76	X, Y Axes
15.	Follow-up	Std.
16.	Position switch (with Victor's own PLC)	Std.
Operation		
1.	Automatic Operation	Std.
2.	MDI Operation	MDI B
3.	DNC Operation	Reader / Puncher Interface is Required
4.	DNC Operation with Memory Card	PCMCIA Card Attachment is Required
5.	Program Number Search	Std.
6.	Sequence Number Search	Std.
7.	Sequence Number comparison and stop	Std.
8.	Buffer Register	Std.
9.	Dry Run	Std.
10.	Single Block	Std.
11.	JOG Feed	Std.
12.	Manual Reference Position Return	Std.
13.	Manual Handle Feed	1 Unit / Each Path
14.	Manual Handle Feed Rate	X1, X10, X100
15.	Z Axis Neglect	Std.
Interpolation		
1.	Positioning	G00
2.	Single Direction Positioning	G60
3.	Exact Stop Mode	G61
4.	Exact Stop	G09
5.	Linear Interpolation	G01
6.	Circular Interpolation	G02, G03 (multi-quadrant is possible)
7.	Dwell	G04
8.	Helical Interpolation	Std.
9.	Skip Function	G31
10.	Reference Position Return	G28
11.	Reference Position Return Check	G27
12.	2nd / 3rd/4th Reference Position Return	Std.
Feed		
1.	Rapid Traverse Rate	Std.
2.	Rapid Traverse Override	F0, 25%, 50%, 100%
3.	Feed Per Minute	G94 (mm / min)
4.	Tangential Speed Constant Control	Std.
5.	Cutting Feed rate Clamp	Std.
6.	Automatic Acceleration / Deceleration	Rapid traverse: linear; Cutting feed: exponential
7.	Rapid traverse Bell-shaped Acc./Deceleration	Std. (G00)
8.	Bell-shaped Acc./Deceleration After Cutting Feed Interpolation	Std. (G01)
9.	Automatic Corner Deceleration	Std. (G64)
10.	Linear Acc/Deceleration After Cutting Feed Interpolation	Std. (G01)
11.	Feed rate Override	0-150%
12.	Jog Override	0-100%
13.	Automatic Corner Override	G62
14.	Feed Stop	Std.
15.	Feed rate clamp by arc radius (G02/G03)	Std.
16.	At advanced preview control	12
Program Input		
1.	EIA / ISO Automatic Recognition	Std.
2.	Label Skip	Std.
3.	Parity Check	Std.
4.	Control In / Out	Std.
5.	Optional Block Skip	1
6.	Max. Programmable Dimension	+8-Digit
7.	Program Number	04-Digit
8.	Sequence Number	N5-Digit
9.	Absolute / Incremental Programming	G90/G91
10.	(Pocket Calculator Type) Decimal Point Programming	Std.
11.	Input Unit 10 Time Multiply	Std.

12.	Plane Selection	G17, G18, G19
13.	Rotary Axis Designation	Std.
14.	Rotary Axis Roll-Over Function	Std.
15.	Polar coordinate Command	G16
16.	Coordinate System Setting	Std.
17.	Automatic Coordinate System Setting	Std.
18.	Workpiece Coordinate System	G52, G53, G54-G59
19.	Addition of Workpiece Coordinate System Pair	48 Pairs
20.	Manual Absolute On And Off	Std.
21.	Optional Chamfering Corner R	Std.
22.	Programmable Data Input	G10
23.	Sub Program Call	10 ldrds nested
24.	Custom macro B	Std.
25.	Addition of Custom Macro Common Variables	#00-#199, #500-#999
26.	Canned Cycles For Milling	G73 / G74 / G76, G80-G89, G98 / G99
27.	Small hole peck drilling cycle	G83
28.	Circular Interpolation by R Programming	Std.
29.	Program Format	FANUC Std. format
30.	Program Stop / Program End	M00 / M01 / M02 / M00
31.	Reset	Std.
32.	Scaling	G51
33.	Coordinate System Rotation	G68
Auxiliary Spindle Speed Function		
1.	Auxiliary Function Lock	Std.
2.	High Speed M / S / T Interface	Std.
3.	Spindle Speed Function	Std.
4.	Spindle Override	50-120%
5.	1st Spindle Orientation	Std.
6.	M Code Function	M3 digit
7.	S Code Function	S5 digit
8.	T Code Function	T2 digit
9.	Rigid Tapping	Std.
Tool Function & Tool Compensation		
1.	Tool Function	T8 digit
2.	Tool Offset Pairs	400
3.	Tool Offset Memory C	STD (D/H codes are separated)
4.	Tool Length Compensation	G43-G44, G45-G48, G49
5.	Cutting Compensation C	Std.
Accuracy Compensation		
1.	Backlash Compensation	Rapid Traverse / Cutting Feed
2.	Stored Pitch Error Compensation	Std.
Edit Operation		
1.	Part Program Storage Length (in total)	512 KB
2.	Number of Registered programs (in total)	400
3.	Part Program Editing / Protect	Std.
4.	Background Editing	Std.
Setting and Display		
1.	Status Display	Std.
2.	Clock Function	Std.
3.	Current Position Display	Std.
4.	Program Display	Program name 31 characters
5.	Parameter Setting and Display	Std.
6.	Self Diagnosis Function	Std.
7.	Alarm Display	Std.
8.	Alarm History Display	25
9.	Operation History Display	Std.
10.	Help Function	Std.
11.	Run Hour and Parts Count Display	Std.
12.	Actual Cutting Feedrate Display	Std.
13.	Display of Spindle Speed and T Code At All Screens	Std.
14.	Graphic Function	Std.
15.	Servo Setting Screen	Std.
16.	Spindle Setting Screen	Std.
17.	Display of Hardware and Software Configuration	Std.
18.	Multi-Language Display	Std.
19.	Data Protection Key	Std.
20.	Erase CRT Screen Display	Std.
21.	Machining Condition Selecting Screen	Std.
22.	Color LCD / MIDI	8.4"
Data Input / Output		
1.	Reader / Puncher Interface	RS-232C Interface
2.	Memory Card Interface	Std.
OPTIONS		
1.	Dynamic graphic display and simple Conversational programming (Manual guide 0)	D
2.	Programmable mirror image (G50.1)	D
3.	ACC	40 blocks
4.	ACC-2	200 blocks

VICTOR's FANUC Oi-TF Type 3 Control Specifications



Standard

ITEM	SPECIFICATION	DESCRIPTION
Controlled Axes		
1.	Controlled Axes	2 Axes (X, Z)
2.	Simultaneous Controlled Axes	Position/Linear Circular Interpolation (2 / 2 / 2)
3.	Linear Input Increment	0.001 mm / 0.0001 inch / 0.01 deg.
4.	Lead Input Increment 1/10	0.001 mm / 0.0001 inch / 0.01 deg.
5.	Max. command value	±99999.999 mm (±9999.9999 in)
6.	HRV Control	Std.
7.	Inch / Metric Conversion	Std. (G20 / G21)
8.	Interlock	All Axes / Each Axis / Cutting Block Start.
9.	Machine Lock	All Axes / Each Axis
10.	Emergency Stop	Std.
11.	Over-travel	Std.
12.	Stored Stroke Check 1	Std.
13.	Mirror Image	Each Axis
14.	Chamfering on/off	Std.
15.	Follow-up	Std.
Operation		
1.	Automatic Operation	Std.
2.	MDI Operation	MDI B
3.	DNC Operation	Reader / Pancher Interface is Required
4.	DNC Operation with Memory Card	PCMCIA Card Attachment is Required
5.	Program Number Search	Std.
6.	Sequence Number Search	Std.
7.	Sequence number comparison and stop	Std.
8.	Buffer Register	Std.
9.	Dry Run	Std.
10.	Single Block	Std.
11.	JOG Feed	Std.
12.	Manual Reference Position Return	Std.
13.	Manual Handle Feed	1 Unit / Each Path
14.	Manual Handle Feed Rate	X1, X10, X100
Interpolation		
1.	Positioning	G90
2.	Threading synchronous cutting	Std.
3.	Multiple Threading	Std.
4.	Threading retract	Std.
5.	Continuous Threading	Std. (G75)
6.	Variable Threading	Std. (G34)
7.	Linear Interpolation	G01
8.	Circular Interpolation	G02, G03 (multi-quadrant is possible)
9.	Dwell	G04
10.	Skip Function	G31
11.	Reference Position Return	G28
12.	Reference Position Return Check	G27
13.	Z RD Reference Position Return	Std.
Feed		
1.	Rapid Traverse Rate	Std.
2.	Rapid Traverse Override	F0, 25%, 50%, 100%
3.	Feed Per Minute	G98 (mm / min)
4.	Feed Per Revolution	G99 (mm / rev)
5.	Tangential Speed Constant Control	Std.
6.	Cutting Feed rate Clamp	Std.
7.	Automatic Acceleration / Deceleration	Rapid traverse: linear, Cutting feed: exponential
8.	Rapid traverse bell-shaped acceleration/deceleration	Std.
9.	Linear accel/deceleration after cutting feed interpolation	Std.
10.	Feed rate Override	0-150%
11.	Jog Override	0-100%
12.	Feed Stop	Std.
Program Input		
1.	Type code EIA / ISO	Std.
2.	Label Skip	Std.
3.	Parity Check	Std.
4.	Control In / Out	Std.
5.	Optional Block Skip	1
6.	Max. Programmable Dimension	±8-Digit
7.	Program Number	04-Digit
8.	Sequence Number	NS-Digit
9.	Absolute / Incremental Programming	G90/G91
10.	Decimal Point Programming / Pocket Calculator Type Decimal Point Programming	Std.
11.	Input Unit 10 Time Multiply	Std.
12.	Diameter/radius programming	Std.
13.	Plane Selection	G17, G18, G19
14.	Automatic Coordinate System Setting	Std.
15.	Workpiece Coordinate System	G52, G53, G54-G59
16.	Direct Drawing Dimension Programming	Std.

17.	G code System A	Std.
18.	Chamfering/Corner R	Std.
19.	Programmable Data Input	G10
20.	Sub Program Call	10 lads nested
21.	Custom Macro B	Std.
22.	Canned Cycles	Std.
23.	Multiple Repetitive Cycle	Std.
24.	Multiple Repetitive Cycle 2 (Pocket profile)	Std.
25.	Canned Cycle for Drilling	Std.
26.	Program Format	FANUC std. format
27.	Program Stop / Program End	M00 / M01 / M02 / M30

Auxiliary Spindle Speed Function:

1.	Auxiliary Function Lock	Std.
2.	High Speed M / S / T Interface	Std.
3.	Spindle Speed Function	Std.
4.	Constant Surface Speed Control	Std.
5.	Spindle Override	50-120%
6.	Actual Spindle Speed Output	Std.
7.	1st Spindle Orientation	Std.
8.	M Code Function	M3 digit
9.	S Code Function	S4 digit
10.	T Code Function	T4 digit
11.	Rigid Tapping (Spindle)	Std.

Tool Function & Tool Compensation

1.	Tool Function	T7-11/16-26lts
2.	Tool Offset Pairs	±6-digit 99 pairs
3.	Tool Nose Radius Compensation	Std. (G40 / G41 / G42)
4.	Tool Geometry/wear Compensation	Std.
5.	Number of Tool Offsets (in total)	99 sets
6.	Automatic Tool Offset	Opt.
7.	Direct Input of Tool Offset Value Measured B	Std.

Accuracy Compensation

1.	Backlash Compensation	Rapid Traverse / Cutting Feed
2.	Stored Pitch Error Compensation	Std.

Edit Operation

1.	Part Program Storage Length (in total)	1280 m
2.	Number of Registerable programs (in total)	400
3.	Part Program Editing	Std.
4.	Program Protect	Std.
5.	Background Editing	Std.
6.	Play back	Std.

Setting and Display

1.	Status Display	Std.
2.	Clock Function	Std.
3.	Current Position Display	Std.
4.	Program Display	Program name 31 characters
5.	Parameter Setting and Display	Std.
6.	Self-Diagnosis Function	Std.
7.	Alarm Display	Std.
8.	Alarm History Display	25
9.	Operation History Display	Std.
10.	Help Function	Std.
11.	Run Hour and Parts Count Display	Std.
12.	Actual Cutting Feedrate Display	Std.
13.	Display Spindle Speed and T Code At All Screens	Std.
14.	Dynamic Graphic Display	Std.
15.	Manual Guide Off	Std.
16.	Servo Setting Screen	Std.
17.	Display of Hardware and Software Configuration	Std.
18.	Multi-Language Display	Std.
19.	Data Protection Key	Std.
20.	Erase CRT Screen Display (Energy saving)	Std.
21.	Spindle Setting Screen	Std.
22.	Color LCD / MDI (Horizontal Type)	8.4"
23.	Dynamic Display Language Switch	Std.

Data Input / Output

1.	Reader / Pancher Interface	RS-232, USB interface
2.	Memory Card Interface	Std.

OPTIONS

1.	Automatic Tool Offset	<input type="checkbox"/>
2.	Manual Guide I	<input type="checkbox"/>
3.	G code system B/C	please specify if required
4.	Type format for FS 15	please specify if required

Vcenter-102E Machine Specifications

Item \ Model	Units	Vcenter-102E
Travel		
X axis travel	mm	1020
Y axis travel	mm	600
Z axis travel	mm	560
Distance		
Spindle center to column	mm	600
Spindle nose to table surface	mm	150 ~ 710
Table		
Table work area	mm	1100 x 510
Dimension of T-slot	mm	5 x 18 x 100
Max. table load	kg	750
Spindle		
Spindle taper		BT-40
Spindle motor - cont / 30min	KW	11/15
Spindle speed	rpm	8000 (opt. 10000)
Feed rate		
Rapid feed rate - X/Y/Z	m/min	24 / 24 / 20
Axis feed motor - X/Y/Z	kW	2.5 / 2.5 / 2.5
Cutting feedrate by table	m/min	7.5
X/Y ballscrew (dia. x pitch)	mm	40 x P12
Z ballscrew	m/min	40 x P10
Tools		
Max. tool length	mm	250
Max. tool weight	kg	7
Magazine capacity		24 (Round)
Max. tool diameter (without adjacent tools)	mm	80
Tool exchange time	sec.	3.5
Pull stud angle	deg.	90 (opt. 45)
Tool selection method		Random
Machine		
Power requirement	kVA	30
Min/Max. air pressure	kg/cm ²	5.5 ~ 6.5
Coolant tank capacity	L.	280
Std. NC controller		FANUC 0i-MF (type 3)
Floor space requirement	mm	2750 x 2485
Max. machine height	mm	2640
Net weight	kg	6100

*Machine and controller specifications are subject to change without notice.

Standard Accessories

- Fully enclosed splash guard
- T nuts for table slot
- Hand tools and toolbox
- Rigid tapping
- High pressure coolants (5 bars/50Hz, 7 bars/60Hz)
- Remote MPG
- 3-step warning light
- Leveling blocks
- Fanuc manuals by CD-ROM

Optional Accessories

- Dynamic graphic display (including Manual guide 0i)
- Spindle oil cooler
- Air conditioner for electric cabinet
- Chip conveyor with cart
- Full 4th axis control
- Auto tool length measurement
- Air gun
- Coolant gun
- Oil skimmer
- Oil mist collector
- Fanuc manuals
- CE marked components

Machine Layout

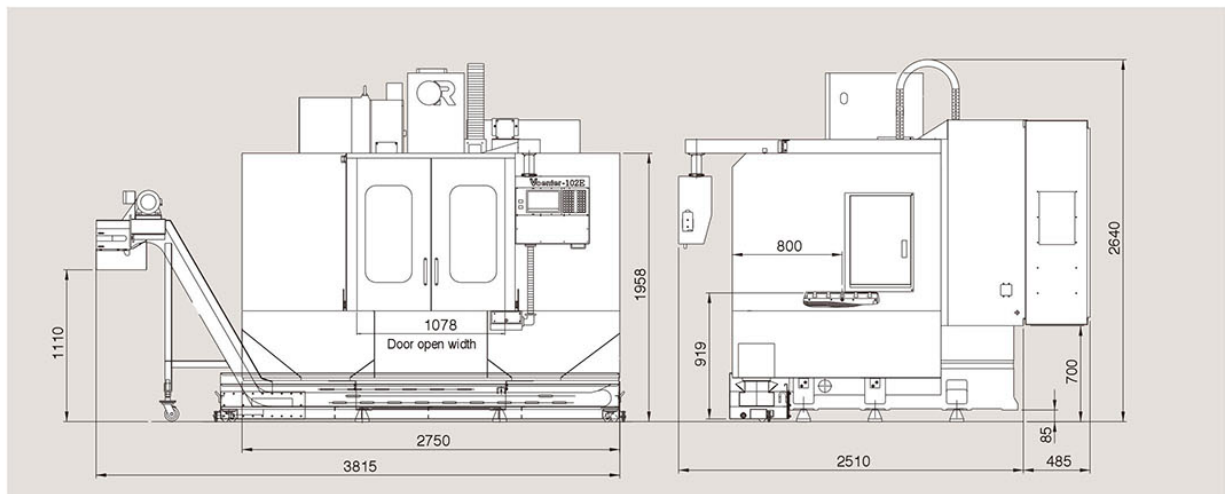

Vcenter-102E Cutting Tests on Mild Steel (S45C)



Face mill $\varnothing 65$ mm



Depth of cut :
4 mm (spindle loading 127%)
312 cc/min

- Spindle speed : 1500 rpm
- Feed rate : 1200 mm/min

Drilling



Drill diameter:
 $\varnothing 35$ mm

- Spindle speed : 545 rpm
- Feed rate : 109 mm/min

Rigid Tapping



Tap spec. :
M30 x P3.5 mm

- Spindle speed : 104 rpm
- Feed rate : 364 mm/min

Machine Options



Spindle oil cooler



Chip conveyor



Oil Skimmer

Tool Shank

BT 40

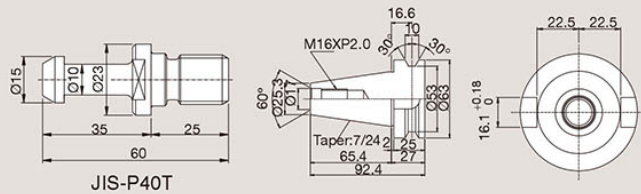

SK 40

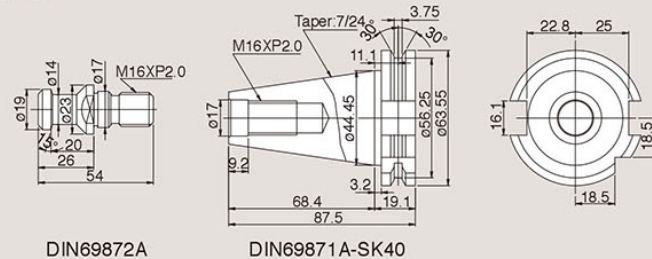

Machining Range

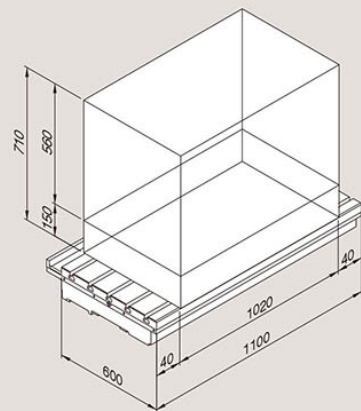

Technical Drawings



Vturn-20E

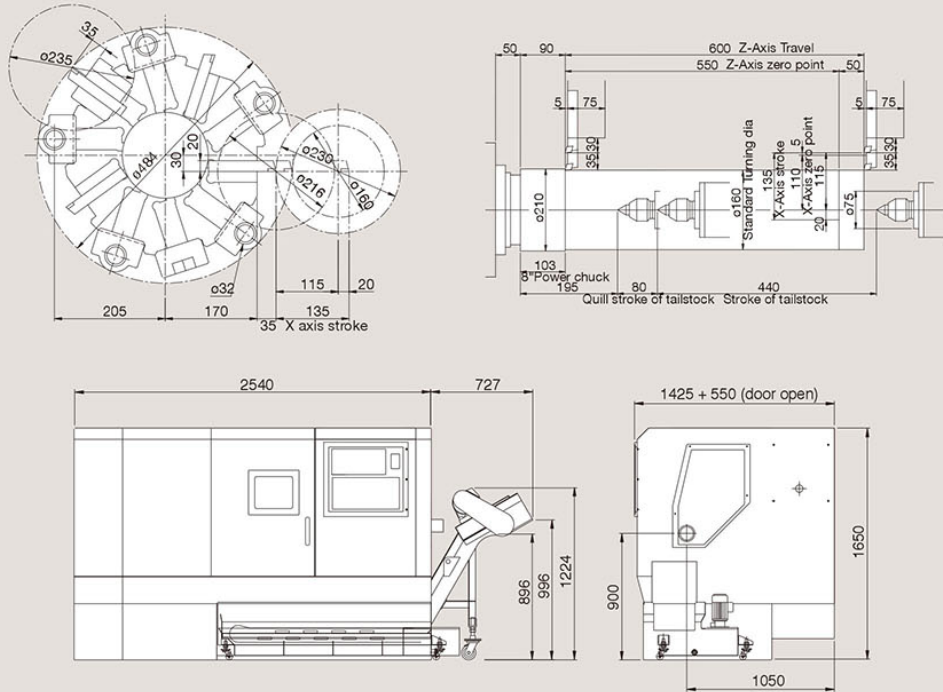

Vturn-26E

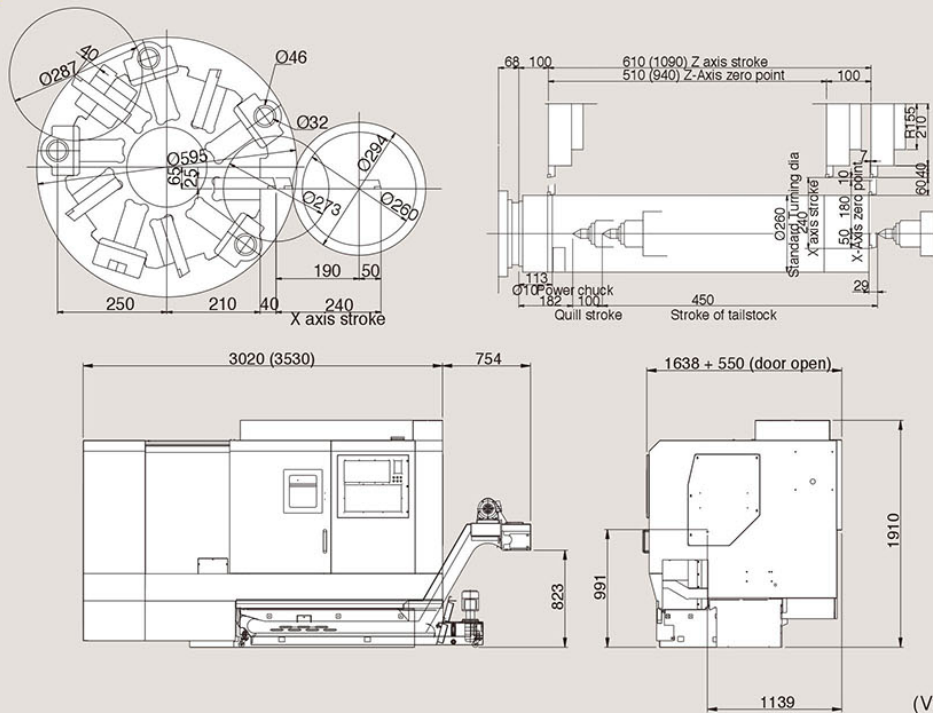

Vturn-20E/26E Machine Specifications

Item \ Model	Units	Vturn-20E	Vturn-26/60E Vturn-26/110E
Machine Capacity			
Swing over bed	mm	450	520
Std. turning dia.	mm	160	260
Max. turning dia.	mm	230	380
Swing over carriage	mm	300	350
Center distance	mm	635	650 1130
Axis Feeds			
X axis travel	mm	115+20	190+50
Z axis travel	mm	600	610 1090
Rapid feed - X/Z axis	m/min	12 / 15	12 / 15
Feed motor - X/Z axis	kW	1.8 / 2.5	2.5 / 2.5
JOG feedrate	mm/min	0 ~ 1260	0~1260
Ball screw dia x pitch	mm	28 x P6 (X) 40 x P10 (Z)	28 x P6 (X) 40 x P10 (Z)
Spindle			
Spindle nose (chuck)	inch	A2-6 (8")	A2-8 (10")
Max. spindle speed	rpm	4200 (opt. 3500)	2500 (opt. 3500)
Spindle motor power (cont/30min)	kW	7.5 / 9.0	15 / 18.5
Bearing inside dia.	mm	100	130
Spindle bore	mm	62	87
Hole through draw bar	mm	52	75
Turret			
No. of tools	no.	10 (opt. 8)	10 (opt. 12)
Tool shank size	mm	20 (opt. 25)	25
Max. boring bar dia.	mm	40	50
Exchange time (T-T)	sec	1	1
Tailstock			
Quill dia.	mm	75	110
Quill stroke	mm	80	100
Quill taper	mm	MT#4	MT#5
Machine			
CNC controller		0i-TF (type 3)	0i-TF (type 3)
Tank capacity	L.	87	100 130
Power requirement	kVA	23	40
Machine dimension	mm	3267 x 1425 x 1650	3774 x 1700 x 2000 4210 x 1700 x 2000
Machine weight	kg	4000	5400 6000

*Machine and controller specifications are subject to change without notice.

Tooling Accessories

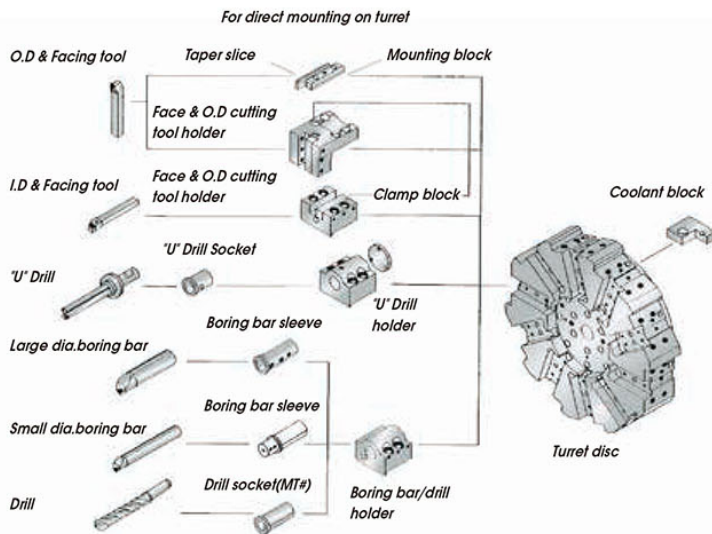

Standard Accessories

- 3-jaw Power chuck with soft jaws
- Programmable tailstock
- Chip conveyor with cart
- Automatic forced lubrication
- Fully enclosed splash guarding
- Tool holders
- 3 step warning light
- FANUC manuals by CD ROM

Optional Accessories

- Hard jaws
- Tailstock center
- Manual tool presetter (Renishaw)
- Higher pressure coolants (3.3 bars/50Hz, 4.7 bars/60Hz)
- Air conditioner for electrical cabinet
- Part catcher
- Bar feeder interface
- Auto door
- Fanuc manuals
- CE marked components

Tool \ Model	Vturn-20E (10 tools)	Vturn-26E (10 tools)
Tool shank for turret disk	20 mm	25 mm
Maximum boring tool diameter	32 mm	50 mm
Face + O.D. cutting tool holder	2	2
Face + I.D. cutting tool holder	1	1
Boring bar tool holder		
32 mm	5	-
40 mm	-	5
50 mm	-	1
Boring bar sleeve		
8 mm	1	-
10, 12, 16, 20, 25 mm	2	2
32 mm	-	2
Drill Socket		
MT-1	Opt.	-
MT-2	1	Opt.
MT-3	Opt.	1
MT-4	-	Opt.
U drill holder		
32 mm	1	-
40 mm	-	1
U drill socket		
20 mm	1	Opt.
25 mm	1	1
32 mm	-	1

*Tooling accessories are subject to change without notice.

Vturn-20E/Vturn-26E Cutting Tests on Mild Steel (S45C)

O.D. Turning



Drilling



Rigid tapping



Depth of cut:

Vturn-20E	Vturn-26E
3 mm (spindle loading 95%) ·Part: Ø150xL.150 mm ·Spindle speed: 456 rpm ·Feed rate: 0.2 mm/rev	6 mm (spindle loading 96%) ·Part: Ø200xL.100 mm ·Spindle speed: 438 rpm ·Feed rate: 0.35 mm/rev

Drill diameter:

Vturn-20E	Vturn-26E
Ø35 mm ·Part: Ø75xL.100 mm ·Spindle speed: 1000 rpm ·Feed rate: 0.15 mm/rev	Ø60 mm ·Part: Ø75xL.100 mm ·Spindle speed: 1000 rpm ·Feed rate: 0.15 mm/rev

Tap spec.:

Vturn-20E	Vturn-26E
M27 x P3.0 mm ·Part: Ø75xL.100 mm ·Spindle speed: 200 rpm ·Feed rate: 600 mm/min	M36 x P4.0 mm ·Part: Ø75xL.100 mm ·Spindle speed: 130 rpm ·Feed rate: 520 mm/min



Vturn-S26CM



Vcenter-P106



Vcenter-H630HS

VictorTaichung profile:
Sales turnover: USD 145 mil's (in 2018)*
No. of employees: 836
*Exchange rate: 1 USD=30 TWD.



HTL



VTL



VMC



HMC



XMT



PMW



THE VICTOR-TAICHUNG COMPANIES

TAIWAN

http://www.victortaichung.com
E-mail: info@mail.or.com.tw

- Victor Taichung Machinery Works Co., Ltd.

Headquarters:

2088, Sec. 4, Taiwan Blvd.,
Taichung, Taiwan, R.O.C.
TEL : 886-4-23592101
FAX : 886-4-23592943

Overseas Marketing Division:

TEL : 886-4-23580701
FAX : 886-4-23584541

UK

- Victor CNC (UK) Ltd.
TEL : 44-1-706-648485
FAX : 44-1-706-648483

FRANCE

- Victor France
TEL : 33-1-64772000
FAX : 33-1-64772063

GERMANY

- Victor GmbH
TEL : 49-2261-478434
FAX : 49-2261-478327

MALAYSIA

- Victor Machinery (M) SDN. BHD.
TEL : 60-3-56337180
FAX : 60-3-56337191

THAILAND

- Victor (Thailand) Co. Ltd.
TEL : 66-2-9263735
FAX : 66-2-9032373

INDONESIA

- PT. Victor Machinery Indonesia
TEL : +62-21-88958504
FAX : +62-21-88958513

USA

- Fortune International Inc.
TEL : 1-732-2140700
FAX : 1-732-2140701

SOUTH AFRICA

- Victor Fortune (PTY) Ltd.
TEL : 27-11-3923800
FAX : 27-11-3923899

CHINA

- Victor Taichung Machinery (Shanghai)
TEL : 86-21-59768018
FAX : 86-21-59768009

VictorTaichung was also marketed under the brand names **VICTOR** (outside North America) and **FORTUNE** MAWAGE19EJ